



HEIDENHAIN



Product Information

ECI 1118
EQI 1130
ECI 1119
EQI 1131

Absolute Rotary
Encoders without
Integral Bearing

ECI/EQI 1100

Absolute rotary encoders

- Synchro flange (70F) for axial mounting
- Blind hollow shaft (82A)
- Without integral bearing
- Mounting-compatible to ECN/EQN 1100 optical rotary encoders and ECI/EBI/EQI 1100 inductive series

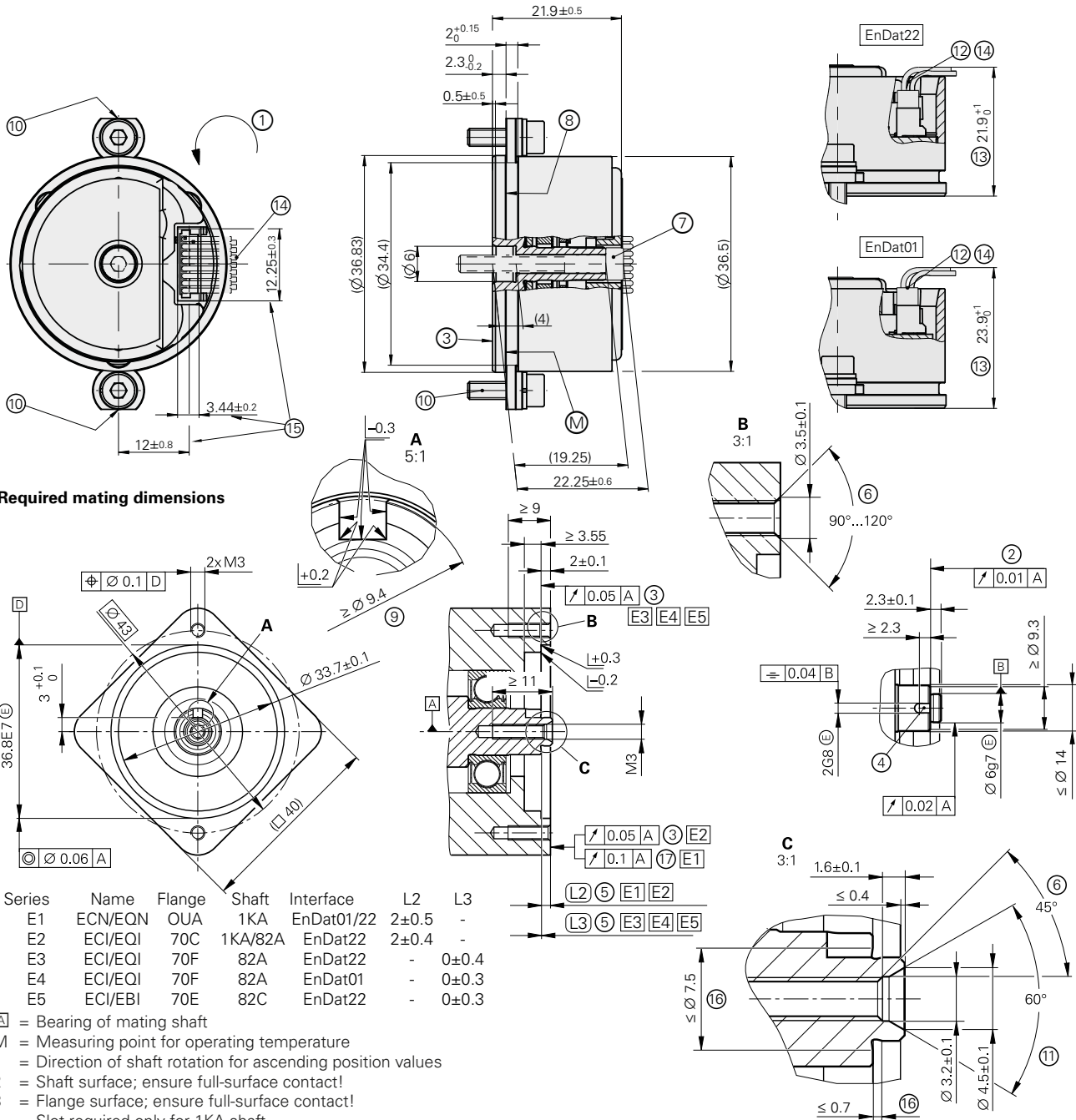

Required mating dimensions

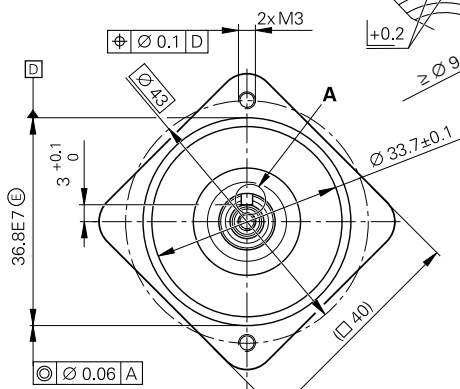

Series	Name	Flange	Shaft	Interface	L2	L3
E1	ECN/EQN	OUA	1KA	EnDat01/22	2±0.5	-
E2	ECI/EQI	70C	1KA/82A	EnDat22	2±0.4	-
E3	ECI/EQI	70F	82A	EnDat22	-	0±0.4
E4	ECI/EQI	70F	82A	EnDat01	-	0±0.3
E5	ECI/EBI	70E	82C	EnDat22	-	0±0.3

- Ⓐ = Bearing of mating shaft
- M = Measuring point for operating temperature
- 1 = Direction is obligatory at start of thread for ascending position values
- 2 = Shaft surface; ensure full-surface contact!
- 3 = Flange surface; ensure full-surface contact!
- 4 = Slot required only for 1KA shaft
- 5 = Maximum permissible deviation between shaft and flange surfaces.
Compensation of mounting tolerances and thermal expansion; ECI/EQI/EBI: Dynamic motion permitted over entire range.
ECN/EQN: ±0.15 mm of dynamic axial motion is permitted
(when ATS software is used for inspecting the mounting, the display value for the mounting clearance is shown as 2 mm instead of as 0 mm)
- 6 = Chamfer is obligatory at start of thread for materially bonding anti-rotation lock
- 7 = Shaft-fastening screw DIN EN ISO 4762 – M3x25 – 8.8 with materially bonding anti-rotation lock: ID 202264-86; tightening torque 1±0.1 Nm
- 8 = Clamping surface
- 9 = Contact surface of slot
- 10 = Optional fastening of the flange via fastening kit, ID 1264352-xx; tightening torque 1±0.1 Nm; pay attention to the orientation of the flat!
- 11 = Possible centering hole
- 12 = 15-pin pin header
- 13 = Dimension for JH standard cable
- 14 = Note the space required for cables
- 15 = Distance to cover; take the opening for pin header, socket connector, and wires into account
- 16 = Undercut
- 17 = Coupling surface of ECN/EQN

mm

 Tolerancing ISO 8015
 ISO 2768 - m H
 6 mm: ±0.2 mm

	Singletum ECI 1118	Multitum EQI 1130	Singletum ECI 1119	Multitum EQI 1131
Valid for ID	1164814-xx	1164815-xx	1164812-xx	1164813-xx
Interface	EnDat 2.1		EnDat 2.2	
Ordering designation*	EnDat01		EnDat22	
Position values per rev.	262 144 (18 bits)		524 288 (19 bits)	
Revolutions	–	4096 (12 bits)	–	4096 (12 bits)
Elec. permissible speed/deviations ¹⁾	≤ 4000 rpm / ±65 LSB ≤ 15 000 rpm / ±200 LSB	≤ 4000 rpm / ±65 LSB ≤ 12 000 rpm / ±164 LSB	–	–
Calculation time t_{cal} Clock frequency	≤ 8 μs ≤ 2 MHz		≤ 5 μs ≤ 16 MHz	
Incremental signals	 1 V _{PP}		–	
Line count	16		–	
Cutoff frequency –3 dB (typical)	≥ 6 kHz		–	
System accuracy	±280"		±120"	
Electrical connection with PCB connector	15-pin		15-pin (with connection for external temperature sensor) ²⁾	
Supply voltage	DC 4.75 V to 10 V		DC 3.6 V to 14 V	
Power consumption (max.)	At 4.75 V: ≤ 600 mW; at 10 V: ≤ 650 mW	At 4.75 V: ≤ 700 mW; at 10 V: ≤ 750 mW	At 3.6 V: ≤ 650 mW; at 14 V: ≤ 700 mW	At 3.6 V: ≤ 750 mW; at 14 V: ≤ 850 mW
Current consumption (typical)	at 5 V: 85 mA (without load)	at 5 V: 100 mA	at 5 V: 95 mA (without load)	at 5 V: 115 mA
Shaft	Blind hollow shaft for axial clamping Ø 6 mm			
Moment of inertia of rotor	0.2 · 10 ⁻⁶ kgm ²			
Angular acceleration of rotor	≤ 1 · 10 ⁵ rad/s ²			
Mech. permiss. speed n	≤ 15 000 rpm	≤ 12 000 rpm	≤ 15 000 rpm	≤ 12 000 rpm
Axial motion of measured shaft	≤ ±0.3 mm		≤ ±0.4 mm	
Vibration 55 Hz to 2000 Hz ³⁾ Shock 6 ms	Stator: ≤ 400 m/s ² ; rotor: ≤ 600 m/s ² (EN 60068-2-6) ≤ 2000 m/s ² (EN 60068-2-27)			
Min. operating temperature	–40 °C			
Max. operating temperature	115 °C		110 °C	
Relative humidity	≤ 93 % (40 °C/21 d as per EN 60068-2-78); without condensation			
Protection EN 60529	IP00 when mounted ⁴⁾			
Mass	≈ 0.04 kg			

* Please select when ordering

- 1) Velocity-dependent deviations between the absolute and incremental signals
- 2) Evaluation optimized for KTY 84-130 temperature sensor
- 3) Constant amplitude at a frequency from 10 Hz to 55 Hz
- 4) Conformity with the EMC Directive must be ensured in the complete system

Mounting

The blind hollow shaft of the rotary encoder is slid onto the motor's drive shaft and fastened with a central screw. The stator is mounted via a centering diameter and fastened appropriately—the manner of fastening can be designed by the customer. A proposed **fastening option**, where the encoder flange is clamped via a fastener kit consisting of a fixing clamp, a spring washer, and a mounting screw, is available from HEIDENHAIN upon request (see *Mounting accessories*).

Mounting accessories

Screws

Screws (central screw, mounting screws) are not included in delivery and can be ordered separately.

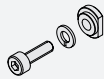
ECI 1119; EQI 1131	Screws ¹⁾	Lot size
Central screw for fastening the shaft	ISO 4762- M3×25-8.8-MKL ¹⁾	ID 202264-86 10 or 100 pieces
Fastener kit for flange	<ul style="list-style-type: none"> • M3 fixing clamp • Spring washer 3 × 0.70 DIN 128A-FS ISO • Screw M3 × 10-8.8 DIN EN ISO 4762 	ID 1264352-01 20 pieces each ID 1264352-02 200 pieces each

1) With coating for materially bonding anti-rotation lock

Please note the information on screws from HEIDENHAIN in the *Encoders for Servo Drives* brochure, under *Rotary encoders with functional safety* in the *General mechanical information* chapter.

Mounting aid

To avoid damage to the cable, use the mounting aid to connect and disconnect the cable assembly. The pulling force must be applied only to the connector of the cable assembly, and not to the wires.

ID 1075573-01

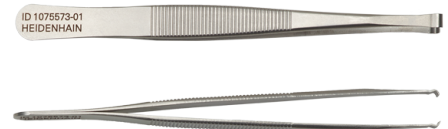





Electrical connection – cable





EnDat01

Output cable inside the motor housing with TPE single wires $12 \times 0.16 \text{ mm}^2$ and heat shrink tubing without shield		
With 15-pin PCB connector, free cable end		ID 640030-xx

EnDat22

Output cables inside the motor housing with TPE single wires $8 \times 0.16 \text{ mm}^2$ and braided sleeve without shield		
Output cable with 15-pin PCB connector and 8-pin M12 straight flange socket (male), with TPE single wires for temperature sensor $2 \times 0.16 \text{ mm}^2$		ID 1119952-xx
Output cable with 15-pin PCB connector and 8-pin M12 straight flange socket (male)		ID 804201-xx
Output cable with 15-pin PCB connector, with TPE single wires for temperature sensor $2 \times 0.16 \text{ mm}^2$, free cable end		ID 1119958-xx

HMC 6 output cable: $\varnothing 3.7 \text{ mm EPG } 1 \times (4 \times 0.06 \text{ mm}^2) + 4 \times 0.06 \text{ mm}^2$		
Output cable with 15-pin PCB connector and contact insert for 6-pin HMC 6 hybrid connecting element (male), with TPE single wires for temperature sensor $2 \times 0.16 \text{ mm}^2$, with cable clamp for shielding connection		ID 1072652-xx

PUR connecting and adapter cables $\varnothing 6 \text{ mm}; 2 \times (2 \times 0.09 \text{ mm}^2) + 2 \times (2 \times 0.16 \text{ mm}^2); A_P = 2 \times 0.16 \text{ mm}^2$		
Connecting cable with 8-pin M12 connector (female) and 8-pin M12 coupling (male)		ID 1036372-xx
Adapter cable with 8-pin M12 connector (female) and 15-pin D-sub connector (female)		ID 1036521-xx
Adapter cable with 8-pin M12 connector (female) and 15-pin D-sub connector (male)		ID 1036526-xx
Connecting cable with 8-pin M12 connector (female), unstripped		ID 1129581-xx ¹⁾

A_P Cross section of power supply lines





1) Connecting element must be suitable for the maximum clock frequency used

Conformity with the EMC Directive must be ensured in the complete system

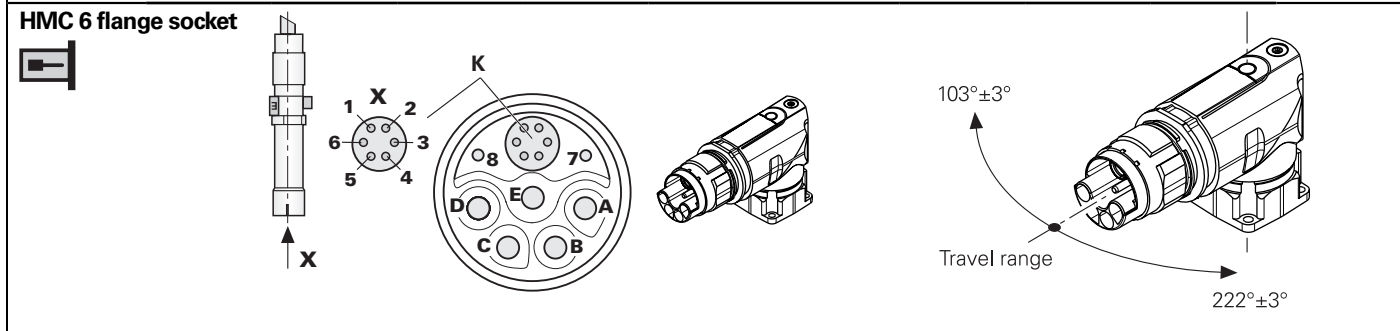
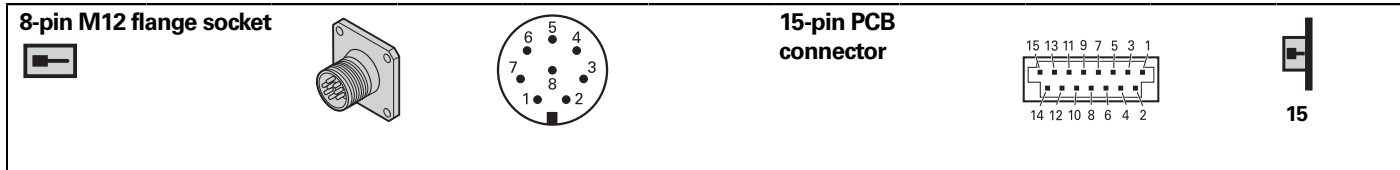
Electrical connection – pin layout



EnDat22



Encoder										
	Voltage supply				Serial data transfer				Other signals ¹⁾	
 M12	8	2	5	1	3	4	7	6	/	/
 HMC 6	1	/	2	/	3	4	5	6	/	/
 15	13	11	14	12	7	8	9	10	5	6
	U_p	Sensor U_p	0 V	Sensor 0 V	DATA	DATA	CLOCK	CLOCK	T_+ ²⁾	T_- ²⁾
	Brown/ Green	Blue	White/ Green	White	Gray	Pink	Violet	Yellow	Brown	Green

1) Only for adapter cables within the motor

2) Connections for external temperature sensor; evaluation optimized for KTY 84-130 (see *Temperature measurement in motors* in the brochure titled *Encoders for Servo Drives*)

Motor							
	Brake		Power				
 HMC 6	7	8	A	B	C	D	E
	BRAKE-	BRAKE+	U	V	W	/	PE
	White	White/Black	Blue	Brown	Black	/	Yellow/Green

External shield of the encoder output cable on communication element housing **K**.
Unused pins or wires must not be assigned!

Electrical connection – pin layout

EnDat01

15-pin PCB connector													
	Voltage supply					Incremental signals				Serial data transfer			
	13	11	14	12	/	1	2	3	4	7	8	9	10
	U_p	U_p sensor	0 V	0 V sensor	Internal shield	A+	A-	B+	B-	DATA	DATA	CLOCK	CLOCK
	Brown/ Green	Blue	White/ Green	White	/	Green/ Black	Yellow/ Black	Blue/ Black	Red/ Black	Gray	Pink	Violet	Yellow

U_p = Voltage supply

The sensor line is connected inside the encoder to the respective power supply.

Vacant pins or wires must not be used!

HEIDENHAIN

DR. JOHANNES HEIDENHAIN GmbH

Dr.-Johannes-Heidenhain-Straße 5

83301 Traunreut, Germany

☎ +49 8669 31-0

☎ +49 8669 32-5061

E-mail: info@heidenhain.de

www.heidenhain.de

This Product Information document supersedes all previous editions, which thereby become invalid. The basis for ordering from HEIDENHAIN is always the Product Information document edition valid when the order is made.



Further information: Adhere to the information in the following documents to ensure the correct and intended operation of the encoder:

- *Encoders for Servo Drives* brochure: 208922-xx
- *Interfaces of HEIDENHAIN Encoders* brochure: 1078628-xx
- *ECI 1118, EQI 1130; ECI 1119, EQI 1131* Mounting Instructions: 1253298-xx